

CLUTCH ADJUSTMENT

▷ BRAVO 500 / SLIDE 800, 1500 and 2000

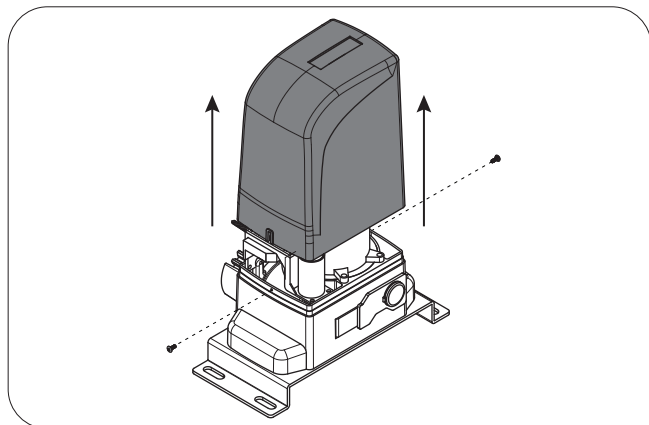

1▶ Unbolt the screws and remove the cover.

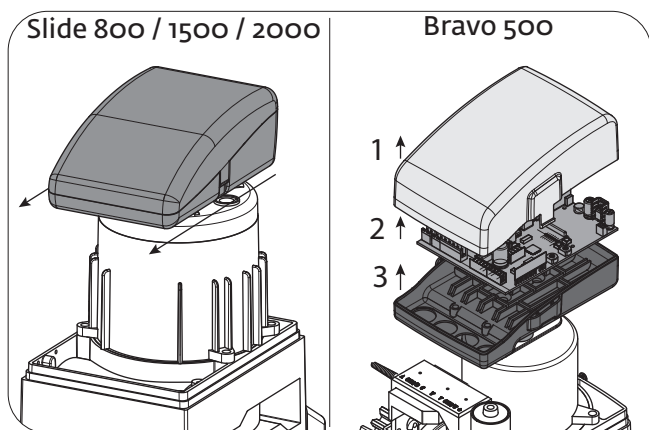

2▶ Access the adjusting screw.

SLIDE 800 / 1500 / 2000 - Slide the central box forward.

BRAVO 500 - Remove the central box's cover. Unbolt the 2 screws of the central and remove it from the box. Now, unbolt the 2 central box fixation screws which connect it to the motor and remove it too. Now you have access to the adjusting screw.

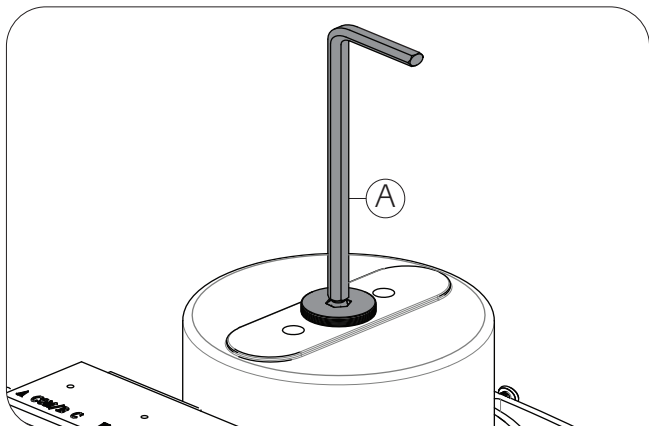

3▶ Adjust the screw in the upper part of the engine. To do this, it will require a 6mm umbrako key as shown in the image (A).

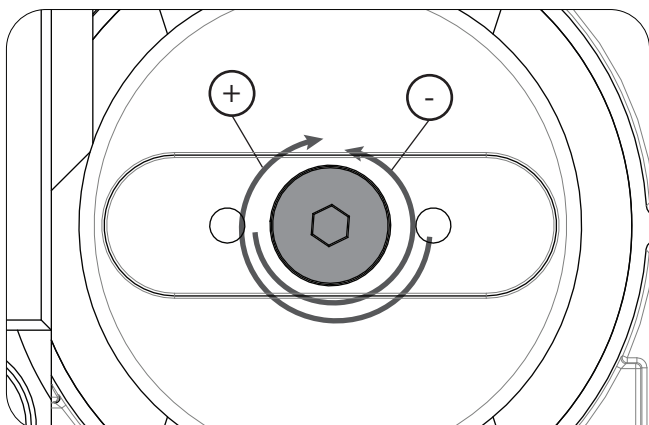

4▶ Do a test to the motor's irreversibility. To do that, just move the gate manually. If the gate is moving, it is necessary to refine the screw by turning clockwise (+).

If the gate does not move at idle, it means that the screw is tightened too much. Turn it counterclockwise (-) until the engine moves the gate at idle.

The tuning must achieve a balance between the gate's irreversibility and the engine's power.