

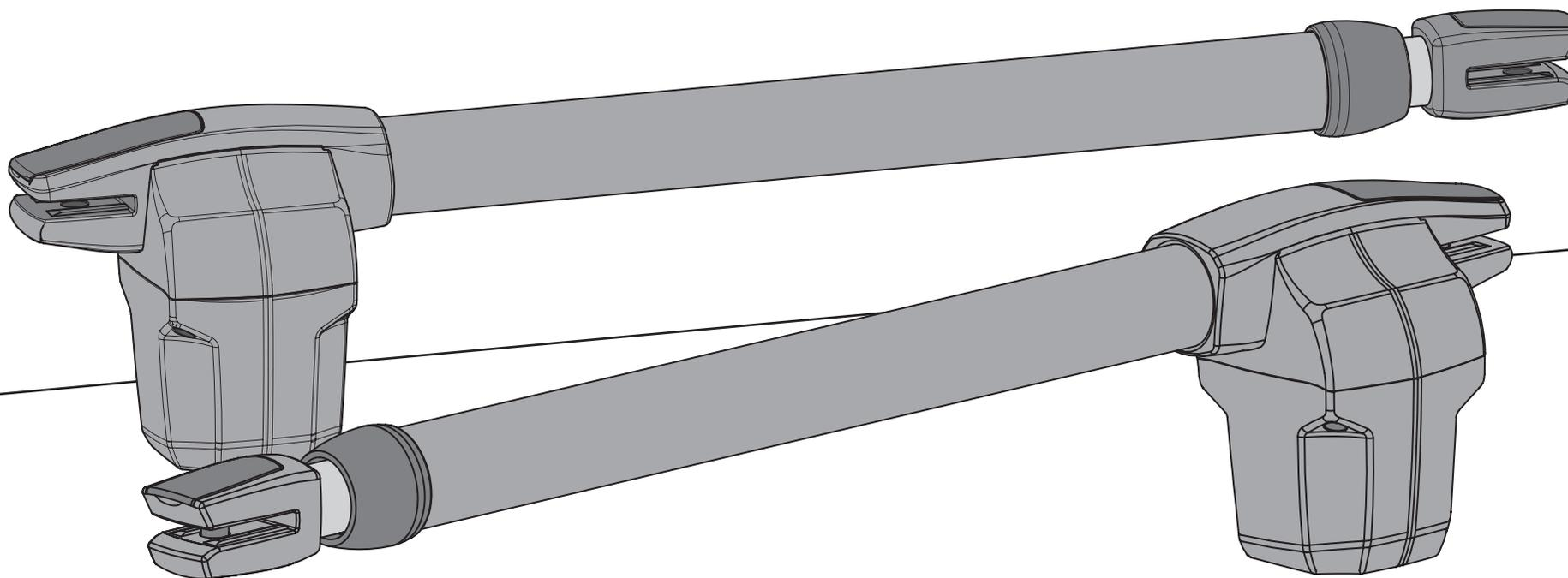

LINCE 230V/110V/24V

USER'S AND INSTALLER'S MANUAL



motorline[®]
PROFESSIONAL

00. CONTENT

INDEX

01. SAFETY INSTRUCTIONS	
STANDARDS TO FOLLOW	01B
02. PACKAGE	
INSIDE PACKAGE	02A
03. OPERATOR	
CHANGE MOTOR DIRECTION	02B
MANUAL RELEASE	03B
TECHNICAL SPECIFICATIONS	04A
04. INSTALLATION	
INSTALLATION DIMENSIONS	04B
INSTALLATION STEPS	06A
INSTALLATION MAP	07
05. TROUBLESHOOTING	
FINAL CONSUMERS INSTRUCTIONS	08
INSTRUCTIONS FOR SPECIALIZED INSTALLERS	08
06. COMPONENTS TEST	
230V/110V MOTOR	09A
24V MOTOR	09B
07. MAINTENANCE	
MAINTENANCE	10A
08. CONTROL BOARD MC2	
CONNECTIONS SCHEME 230V/110V	11
09. CONTROL BOARD MC11	
CONNECTIONS SCHEME 24V	12

01. SAFETY INSTRUCTIONS

STANDARDS TO FOLLOW

ATTENTION:

- To ensure the safety of people, it is important that you read all the following instructions. Incorrect installation or incorrect use of the product can cause physical injury and material damage.
- Keep these instructions in a safe place for future reference.
- This product was designed and produced strictly for the use indicated in this manual. Any other use, not expressly indicated here, could compromise the good condition/operation of the product and/or be a source of danger.
- **ELECTROCELOS S.A.** is not responsible for the improper use of the product, or other use than that for which it was designed.
- **ELECTROCELOS S.A.** is not responsible if safety standards were not taken into account when installing the equipment, or for any deformation that may occur to it.
- **ELECTROCELOS S.A.** is not responsible for the safety and proper operation when using components not sold by them.
- Do not make any modifications to the operator components and / or their accessories.
- Before installation unplug the automatism from the source of power.
- The installer must inform the client how to handle the product in case of emergency and provide this manual to user.
- Keep remote controls away from children, to prevent the automated system from being activated involuntarily.
- The customer shall not, under any circumstances, attempt to repair or tune the operator. Must call qualified technician only.
- Connect the automatism to a 230V/110V plug with ground wire.
- Operator for outdoor and indoor use.

02. PACKAGE

INSIDE PACKAGE

In the package you will find the following components:

- 01• 02 Swing operators LINCE
- 02• 01 Control Board
- 03• 02 transmitters
- 04• 02 Front supports
- 05• 02 Rear supports
- 06• 02 Capacitors [only available with the 230V (8 μ F) and 110V(20 μ F) models]
- 07• 01 Photocells
- 08• 01 User's manual
- 09• 02 Release keys

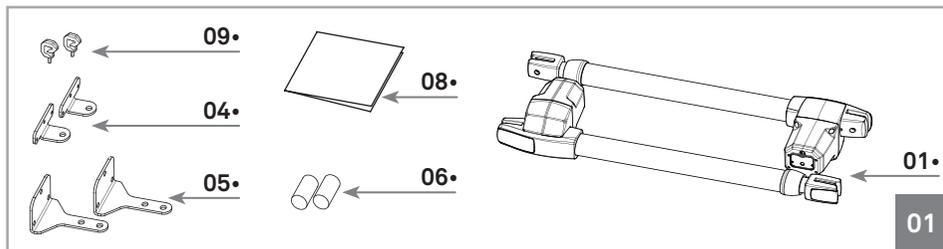

Electronic components the kit:

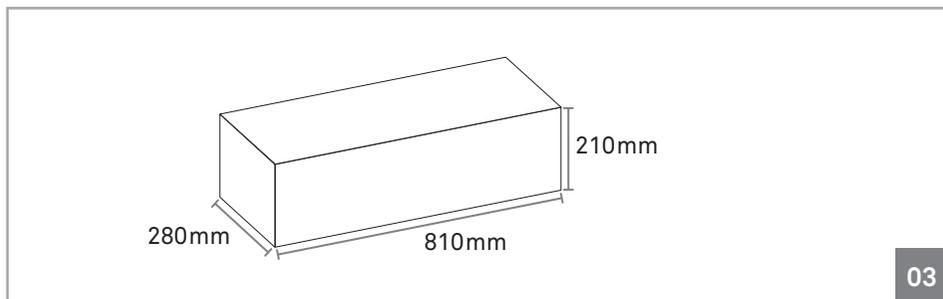
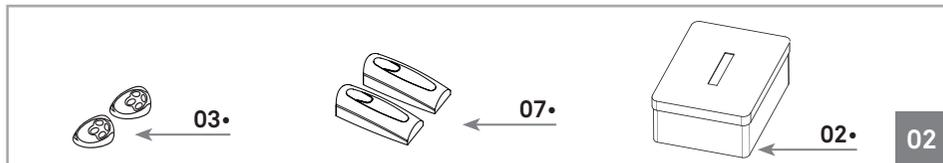

03. OPERATOR

CHANGE MOTOR DIRECTION

The operator **LINCE**, is a product developed exclusively for the automatic opening of swing gates.

Besides being practical, safe and powerful, this product has a new function incorporated so that you can transform a motor to apply on right leaves to left leaves. This allows greater flexibility in the use of each operator.

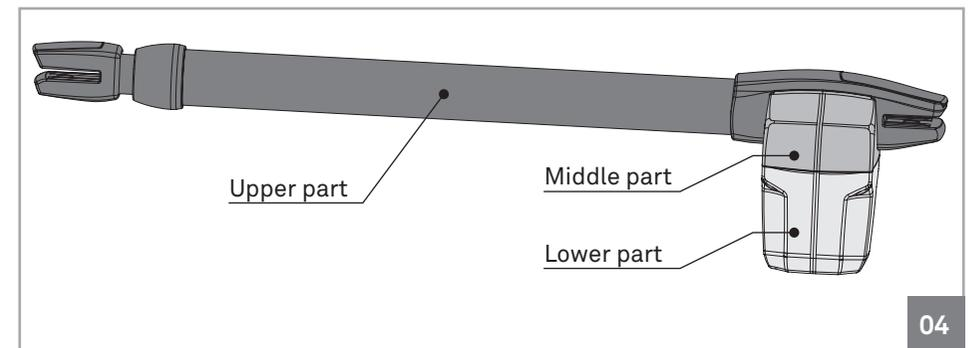

Motor disassembly and assembly process, in order to transform motor, must be done as follows:

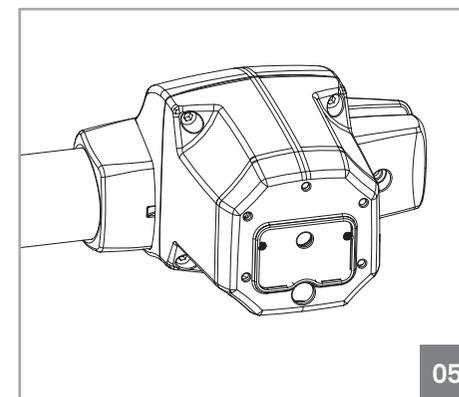

01 • Loosen the screws that secure the Lower Part to Middle Part

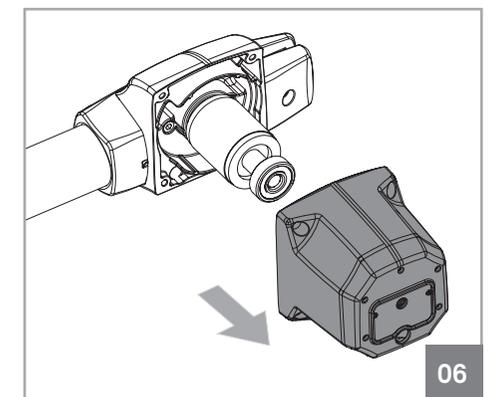

02 • Remove Lower Part

03. OPERATOR

CHANGE MOTOR DIRECTION

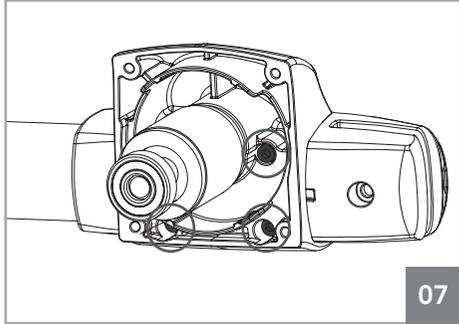

07

03 • Loosen the screws of the Middle Part

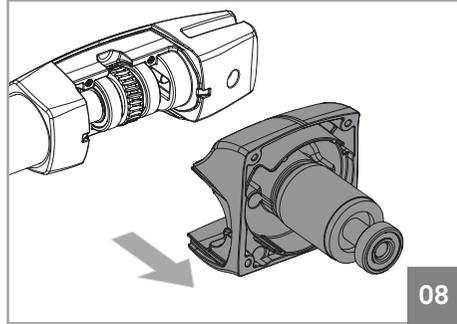

08

04 • Remove Middle Part

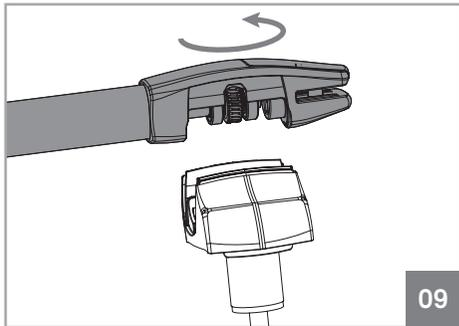

09

05 • Rotate Upper Part 180°

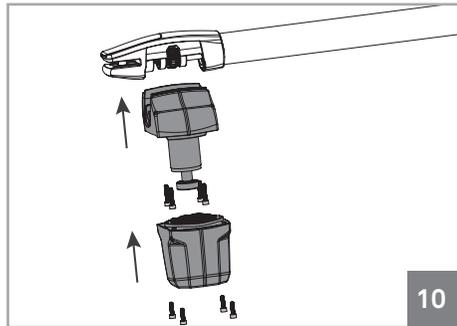

10

06 • Assemble operator by tightening all components with the screws

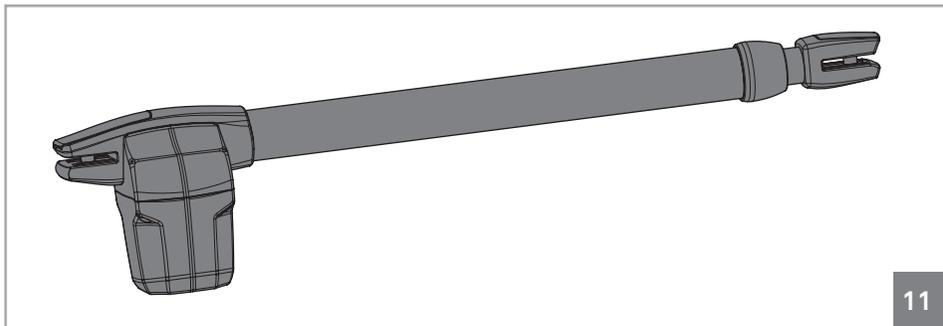

11

07 • Full transformed operator

03. OPERATOR

UNLOCK OPERATOR

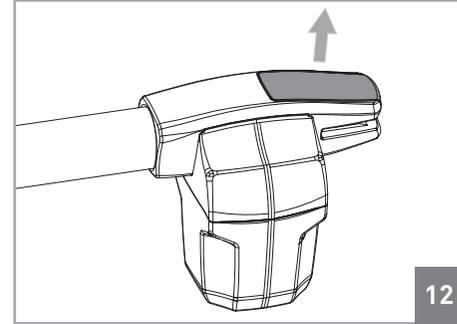

12

01 • Remove the plastic cap from the rear end

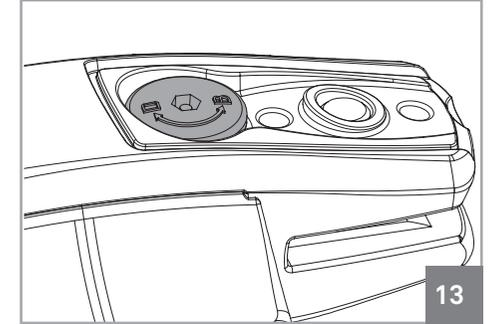

13

Information engraved on the unlock shaft
D=Unlock || B=Lock

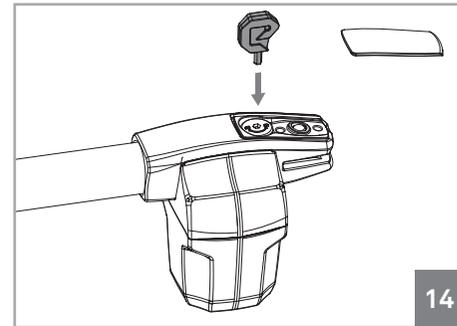

14

02 • Insert Release key on the unlock shaft.

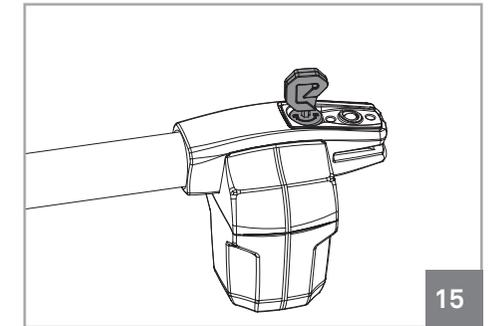

15

03 • Rotate key 180° in the direction indicated in the figure to unlock

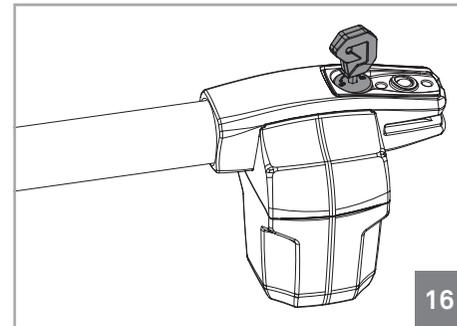

16

04 • Operator unlocked.

Note • To lock operator so it can work automatically, must do it by turning the key anticlockwise.

03. OPERATOR

TECHNICAL SPECIFICATIONS

LINCE specifications are as follow:

		LINCE300	LINCE400	LINCE600
• Power Supply	230V	AC 230V 50/60Hz	AC 230V 50/60Hz	AC 230V 50/60Hz
	110V	AC 110V 50/60Hz	AC 110V 50/60Hz	AC 110V 50/60Hz
	24V	DC 24V	DC 24V	DC 24V
• Power	230/110V	180W	180W	180W
	24V	60W	60W	60W
	230V	1,3A	1,3A	1,3A
• Current	110V	2,5A	2,5A	2,5A
	24V	1A to 3A	1A to 3A	1A to 3A
	230/110V	1400 RPM	1400 RPM	1400 RPM
• RPM	24V	1600 RPM	1600 RPM	1600 RPM
	• Noise level	<50dB	<50dB	<50dB
• Force		2300N	2300N	2300N
• Operating temperatures		-25°C to 75°C	-25°C to 75°C	-25°C to 75°C
• Thermal protection		120°C	120°C	120°C
• Protection class		IP54	IP54	IP54
• Working frequency	230/110V	25%	25%	25%
	24V	Intensive	Intensive	Intensive
• Course		300mm	400mm	600mm
• Max leaf length		2500mm	3000mm	4000mm
• Capacitor	230V	8µF	8µF	8µF
	110V	20µF	20µF	20µF

LINCE 300 || 400 || 600 dimensions are the following:

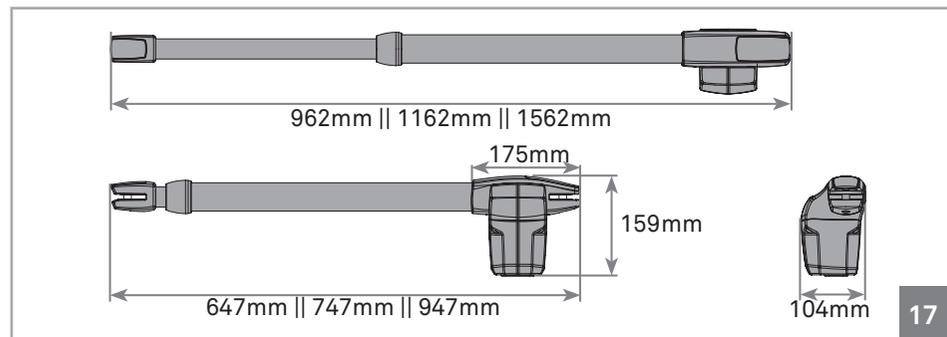

17

04. INSTALLATION

VERTICAL INSTALLATION DIMENSIONS

The operator LINCE must be installed with a small inclination, to prevent water infiltration through the extension arm.

For this, the front support must be fixed to the gate with a height lower than the height of the rear support. See example below:

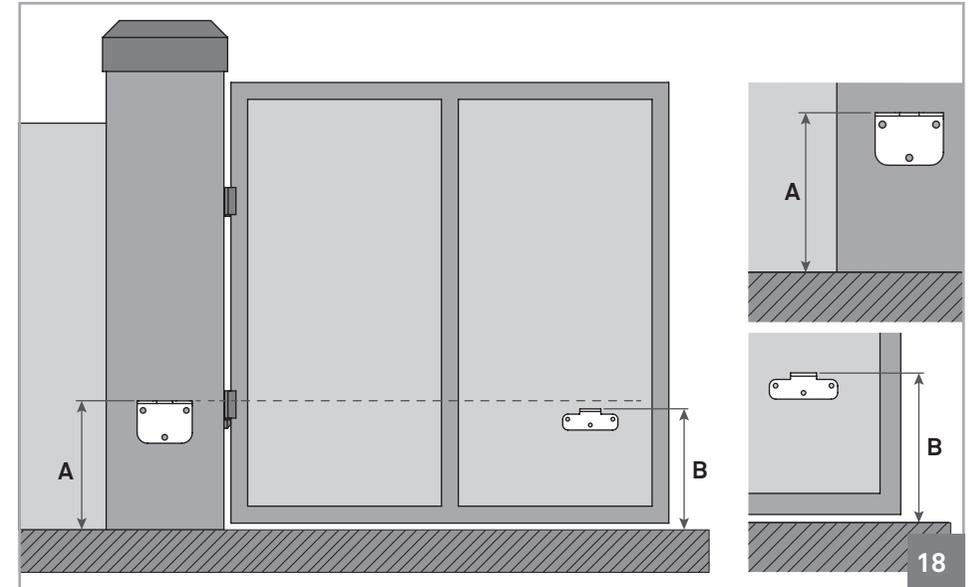

Dimension A • Vertical distance from the floor to the top of the rear support .

Dimension B • Vertical distance from the floor to the top of the front support.

A

? mm

• Set **dimension A** (this can be any size of your choice).

B

A-10mm

• After you set **dimension A**, subtract **10mm** to find **dimension B**.

Example:

• If the height of the rear bracket (**dimension A**) is set at 600 mm, then the height of the front bracket (**dimension B**) will be 590 mm (600mm-10mm).



It is very important that these dimensions are respected! Only this way can be assured the correct functioning and durability of the operators!
It is also very important to have a levelled ground/terrain!

4B

EN

04. INSTALLATION

VERTICAL INSTALLATION DIMENSIONS

On the illustrated diagrams below and on the next page, are the **horizontal dimensions for the installation** of the automated system.

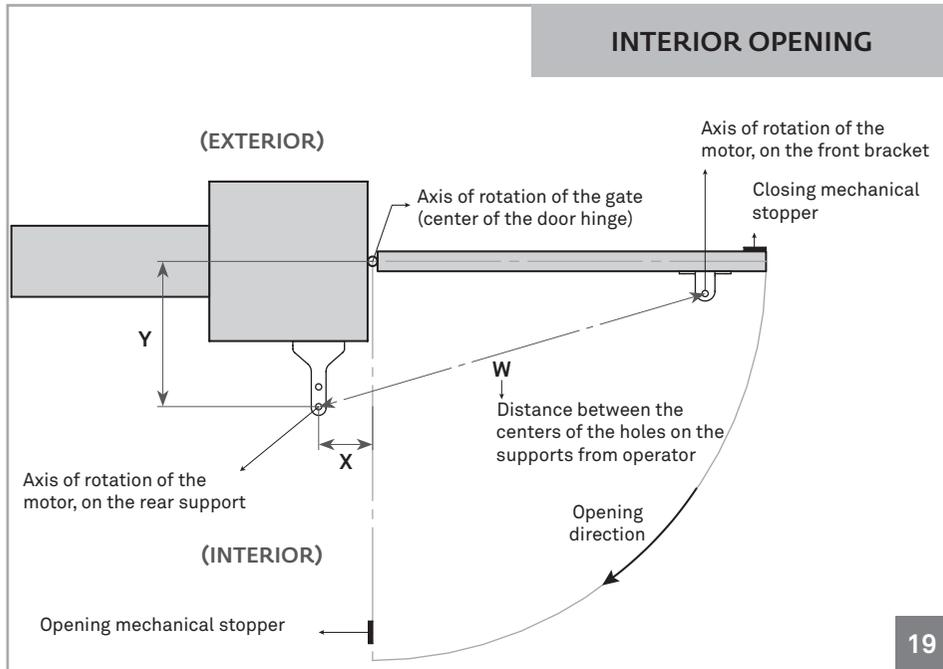

19

	Opening angle	X	Y	W
• LINCE300	95°	120 a 180	120 a 180	895 a 900
• LINCE400	95°	120 a 180	120 a 180	1095 a 1100
	120°	160 a 180	120 a 140	1095 a 1100
• LINCE600	95°	120 a 350	120 a 200	1495 a 1500
	120°	200 a 280	120 a 200	1495 a 1500



It is very important that these dimensions are respected! Only this way can be assured the correct functioning and durability of the operators!

04. INSTALLATION

HORIZONTAL INSTALLATION DIMENSIONS

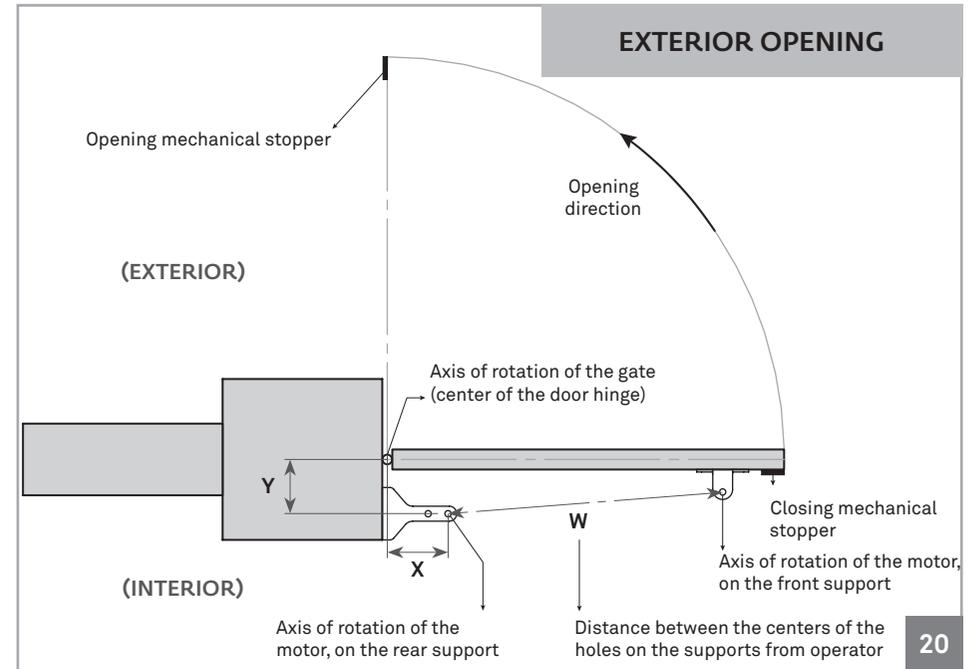

20

	Opening angle	X	Y	W
• LINCE300	95°	120 a 180	120 a 180	595 a 600
• LINCE400	95°	160 a 200	120 a 180	695 a 700
• LINCE600	95°	160 a 300	120 a 280	900 a 905

Legend:

Dimension X - Horizontal distance between hinge axis of the door and the rear axle of the motor.

Dimension Y - Vertical distance between hinge axis of the door and the rear axle of the motor.

Dimension W - Distance between axis of the motor brackets.

04. INSTALLATION

INSTALLATION STEPS



Pay attention to installation dimensions mentioned on pages 04B, 05A and 05B!

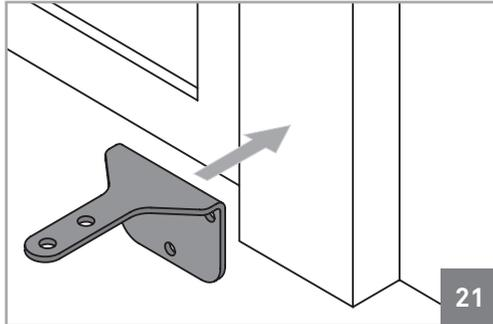

01 • Fixing rear support

- The **Rear support** must be fixed to the pillar or wall using dimensions provided in the preceding pages. It can be fixed using screws with mechanical bushing or chemical welding process, or one of your choice since it provides an appropriate support.

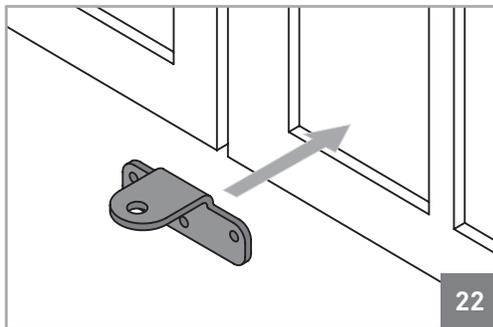

02 • Fixing front support

- The **Front support** should be fixed to the gate, respecting height dimensions and distance to the rear support. This may be fixed by using screws, welding process, or to choose another long as it provides a secure proper support.

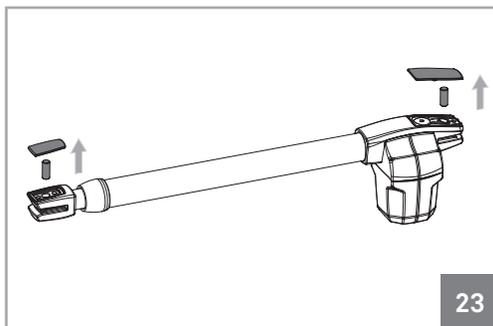

03 • Remove caps and pins from motor

- Before installing motor, remove caps and pins from motor.
- At the end of the installation, put back plastic covers for a better visual finish of the operator.

04. INSTALLATION

INSTALLATION STEPS

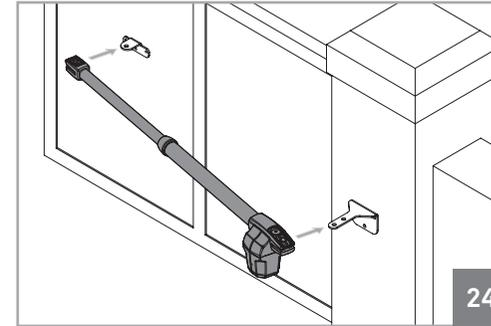

04 • Install operator on the supports

- The operator must be placed on both supports the same time to avoid leaving the operator suspended by only one of the supports.

To make the task easier, you should unlock the operator in order to be able to stretch / retract arm easily (see page 03B), to get the correct position for supports.

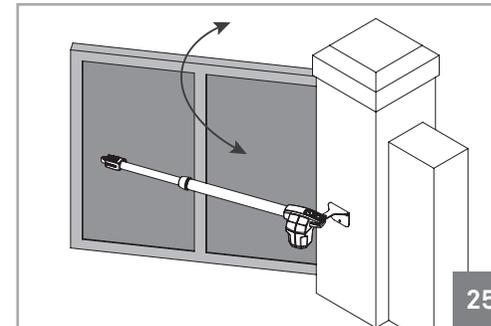

05 • Test movement

- Install the pins removed earlier on each place with a small amount of lubricant for less friction.
- Move the door manually to see if the door opens and closes uniformly and correctly, without any irregular friction during its entire travel; This will ensure that operator is not subjected to problems during operation.

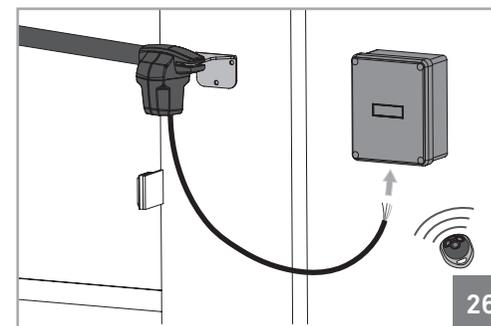

06 • Connecting operator to control board and configuring control devices.

- With the operator installed, connect it to control board for system configuration (see control board user manual). Must also configure the desired control devices (transmitters, wall switch, etc.) and other additional components such as antenna, warning light, key selector, among others.



It is important to respect this installation order!

Otherwise, it is not possible to ensure correct installation and operators may not work properly!

04. INSTALLATION

INSTALLATION MAP

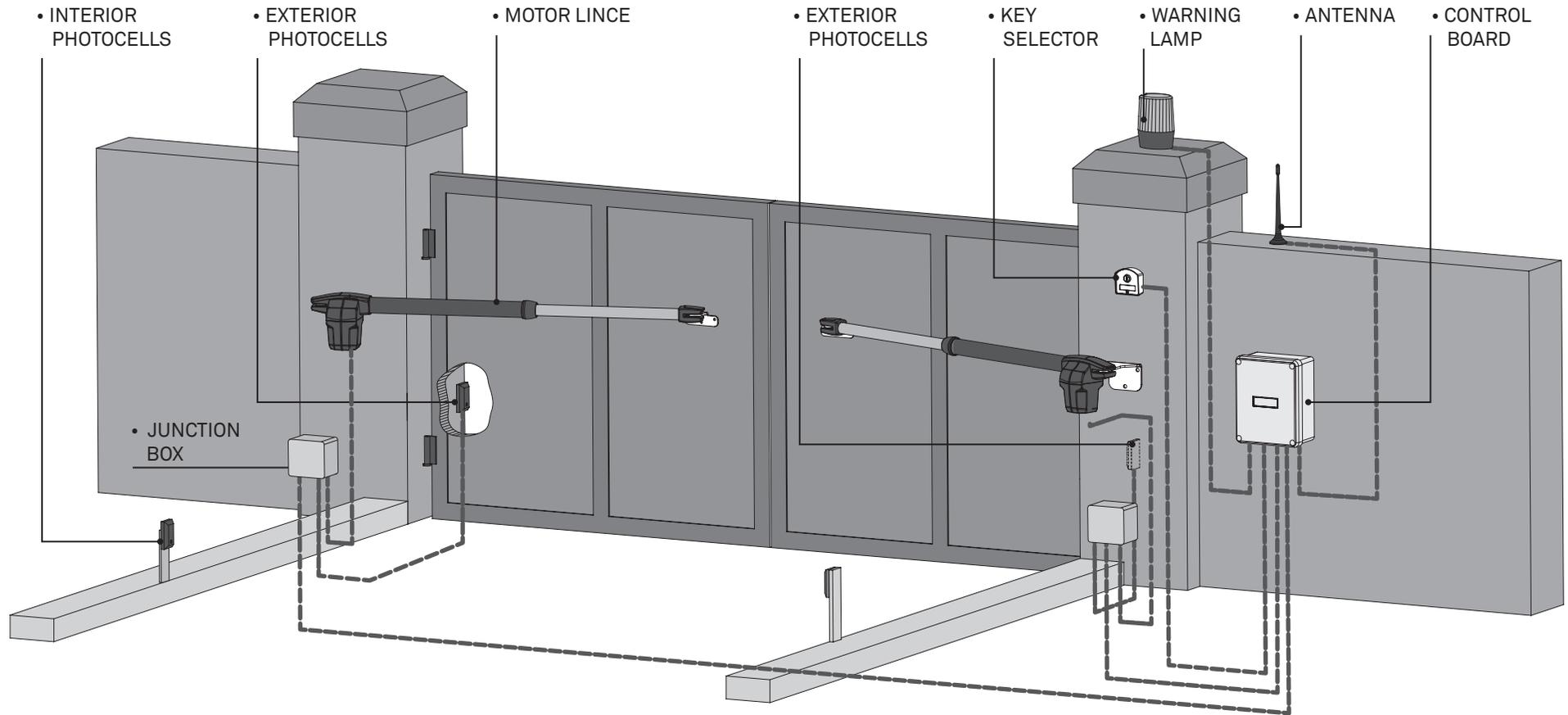

LEGEND:

----- • Connection cables



It is important to use mechanical stoppers in the opening and closing position of the gate. If not respected, components of the automation may suffer efforts for which they were not prepared, and as a result will be damaged.



It is important to use junction boxes for connections between motors, components and control unit. All cables must enter and exit on the bottom of the junction and control board box.

05. TROUBLESHOOTING

FINAL CONSUMERS INSTRUCTIONS

INSTRUCTIONS FOR SPECIALIZED INSTALLERS

Anomaly	Procedure	Behavior	Procedure II	Discovering the origin of the problem			
• Motor doesn't work at all	• Make sure you have power in the automation control board and if it is working properly.	• Still not working	• Consult a qualified MOTORLINE technician.	1 • Open control box and check if it has 230V/110V/24V power supply; 2 • Check input fuses;	3 • Disconnect motors from control board and test them by connecting directly to power supply in order to find out if they have problems (see page 09A/09B).	4 • If the motors work, the problem is on the control board. Pull it out and send it to our MOTORLINE technical services for diagnosis;	5 • If the motors doesn't work, remove them from installation site and send to our MOTORLINE technical services for diagnosis.
• Motor doesn't move but makes noise	• Unlock motor and move gate by hand to check for mechanical problems on the gate.	• Is the gate closed?	• Consult an experienced gate expert	1 • Check all motion axis and associated motion systems related with gate and operators (pins, hinges, etc.) to find out what is the problem.			
		• Gate moves easily?	• Consult a qualified MOTORLINE technician.	1 • Check capacitors, testing operator with new capacitors;	2 • If capacitors are not the problem, disconnect motors from control board and test them by connecting directly to power supply in order to find out if they have problems (see page 09A/09B).	3 • If the motors work, the problem is from control board. Pull it out and send it to our MOTORLINE technical services for diagnosis;	4 • If the motors doesn't work, remove them from installation site and send to our MOTORLINE technical services for diagnosis.
• Motor opens but doesn't close	• Unlock motor and move gate by hand to closed position. Lock motor(s) again and turn off power supply for 5 seconds. Reconnect it and send order to open gate using transmitter.	• Gate opened but didn't close again.	1 • Check if there is any obstacle in front of the photocells; 2 • Check if any of the control devices (key selector, push button, video intercom, etc.) of the gate are jammed and sending permanent signal to control unit; 3 • Consult a qualified MOTORLINE technician.	All MOTORLINE control boards have LEDs that easily allow to conclude which devices are with anomalies. All safety devices LEDs (DS) in normal situations remain On. All "START" circuits LEDs in normal situations remain Off. If LEDs devices are not all On, there is some security systems malfunction (photocells, safety edges), etc. If "START" circuits LEDs are turn On, there is a control device sending permanent signal.	A) SECURITY SYSTEMS: 1 • Close with a shunt all safety systems on the control board (check manual of the control board in question). If the automated system starts working normally check for the problematic device. 2 • Remove one shunt at a time until you find the malfunction device . 3 • Replace it for a functional device and check if the operator works correctly with all the other devices. If you find another one defective, follow the same steps until you find all the problems.	B) START SYSTEMS: 1 • Disconnect all wires from START terminal input. 2 • If the LED turned Off, try reconnecting one device at a time until you find the defective device. NOTE: n case procedures described in sections A) and B) don't result, remove control board and send to our technical services for diagnosis.	
• Motor doesn't make complete route	• Unlock motor and move gate by hand to check for mechanical problems on the gate.	• Encountered problems?	• Consult an experienced gate expert	1 • Check all motion axis and associated motion systems related with gate and operators (pins, hinges, etc.) to find out what is the problem.			
		• Gate moves easily?	• Consult a qualified MOTORLINE technician.	1 • Check capacitors, testing with new capacitors; 2 • If capacitors are not the problem, disconnect motors from control board and test them by connecting directly to power supply in order to find out if they are faulty; 3 • If the motors doesn't work, remove them from installation site and send to our MOTORLINE technical services for diagnosis.	4 • If motors work well and move gate at full force during the entire course, the problem is from controller. Set force using trimmer on the board. Make a new working time programming, giving sufficient time for opening and closing with appropriate force (see manual of the controller in question).	5 • If this doesn't work, remove control unit and send it to MOTORLINE technical services.	NOTE: Setting force of the controller should be sufficient to make the gate open and close without stopping, but should stop with a little effort from a person. In case of safety systems failure, the gate shall never cause physical damaged to obstacles (vehicles, people, etc.).

06. COMPONENTS TEST

230V/110V MOTOR

To detect if the malfunction is on the control board or on the motor is, sometimes, necessary to perform tests with connection directly to a 110V/230V power supply. For this, it is necessary to interpose a capacitor on the connection in order to the automatism to work (check the type of capacitor to be used in the product manual). The diagram below, shows how to make that connection and how to merge the different components wires.

NOTES:

- To perform the tests, there is no need to remove the automatism from the place it is installed, because in this way, it is possible to understand if the automatism can function properly connected directly to the current.
- You should use a new capacitor during this test to ensure that the problem does not lie on it.

- 01 • Connect the power wires to the terminal, as shown below.
- 02 • Connect the automatism wires in the terminal, interposing a capacitor in the opening and closing wires.
- 03 • Once these connections are completed, connect to a 110V/230V power outlet, depending on the motor / control board in test.

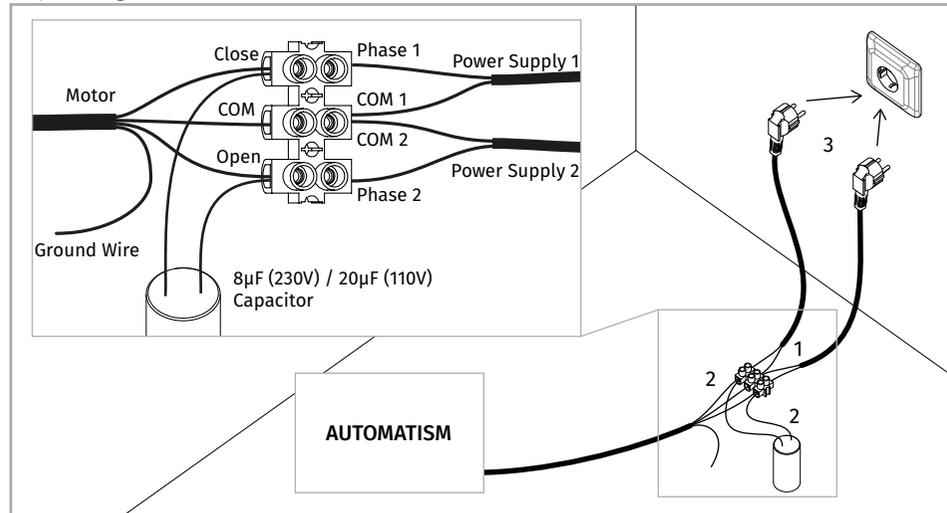

All tests must be performed by qualified personnel due to serious danger associated with the misuse of electrical systems!

06. COMPONENTS TEST

24V MOTOR

To detect which are the components with problems in a 24V LINCE automatism installation, it's sometimes necessary to run a test directly to an external power supply (another 24V battery).

The diagram below shows how to connect the motor to the battery.

NOTES:

- To make these tests it isn't necessary to remove it from the location where it is installed, because in this way, you can understand if the automatism works properly directly connected to the external battery.
- Once you connect the wires to a 24V battery, the motor must work for one direction. To test the opposite movement, change the position of the wires connected to the battery.

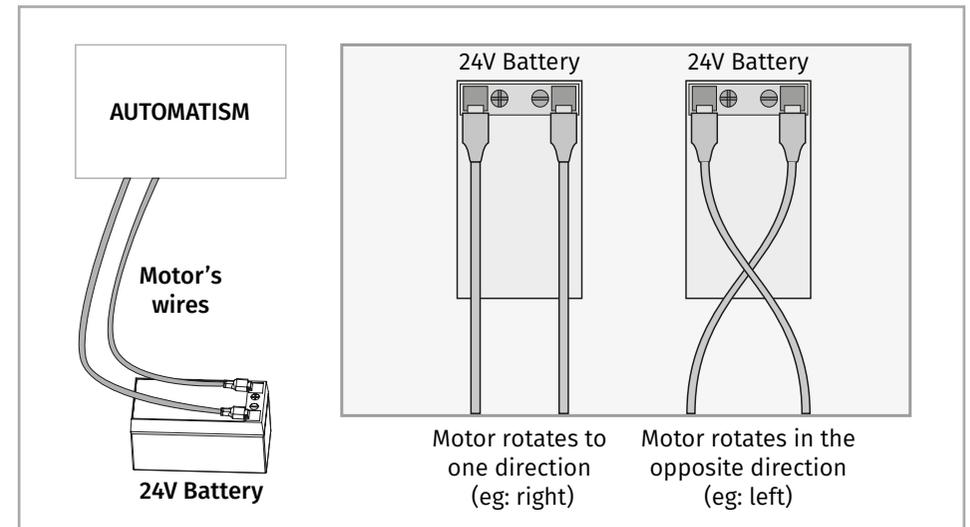

All tests must be performed by qualified personnel due to serious danger associated with the misuse of electrical systems!

07. MAINTENANCE

MAINTENANCE

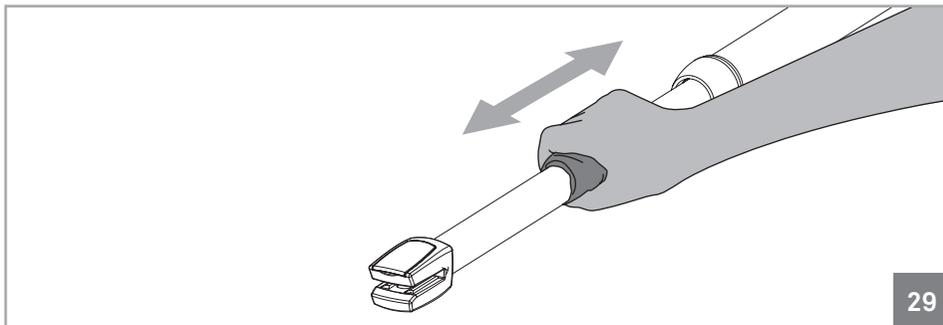

• Clean stainless steel arm

- With a cloth soaked in lubricant spray, wipe any residue that accumulates on the operator's stainless steel arm.
- Apply a small amount of spray lubricant on the arm and using a dry cloth remove the excess, leaving a homogeneous layer of lubricant over the arm.

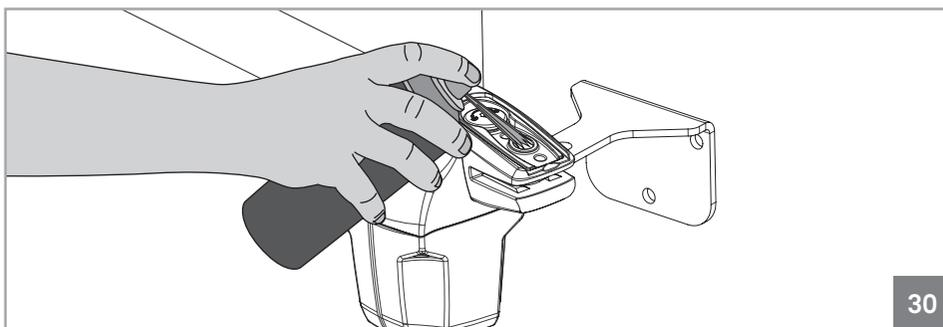

• Lubricate pins

- Remove front and rear caps
- Place a small amount of lubricant on the holes that contains support pins.
- Install caps on the respective holders.

07. MAINTENANCE

MAINTENANCE

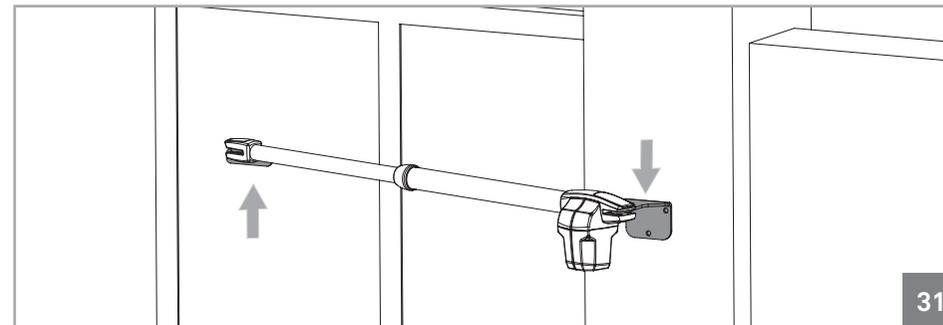

• Check motor supports

- Make sure that supports remain well fixed on the pillars and gate to ensure proper functioning of the equipment.vz



These maintenance measures must be applied every year in order to insure proper functioning of the automated system.

08. CONTROL BOARD MC2

230/110V CONNECTIONS SCHEME

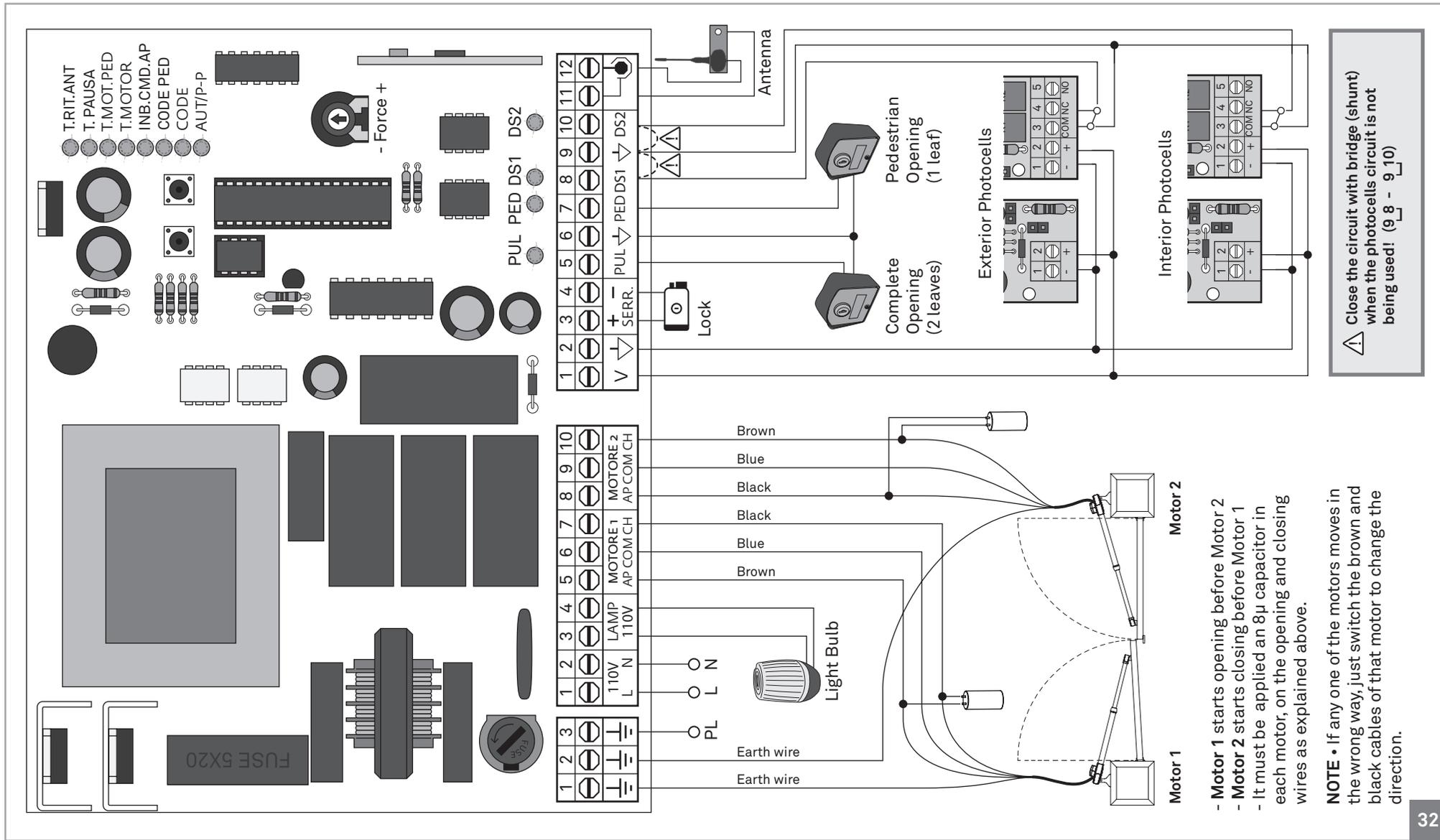

- Motor 1 starts opening before Motor 2
- Motor 2 starts closing before Motor 1
- It must be applied an 8μ capacitor in each motor, on the opening and closing wires as explained above.

NOTE • If any one of the motors moves in the wrong way, just switch the brown and black cables of that motor to change the direction.

09. CONTROL BOARD MC11

24V CONNECTIONS SCHEME

